



**DASTECS** S.R.L.

**Representantes / Distribuidores Exclusivos**

Buenos Aires, Argentina

Tel.: (54 - 11) 5352-2500

Email: [info@dastecsrl.com.ar](mailto:info@dastecsrl.com.ar)

Web: [www.dastecsrl.com.ar](http://www.dastecsrl.com.ar)

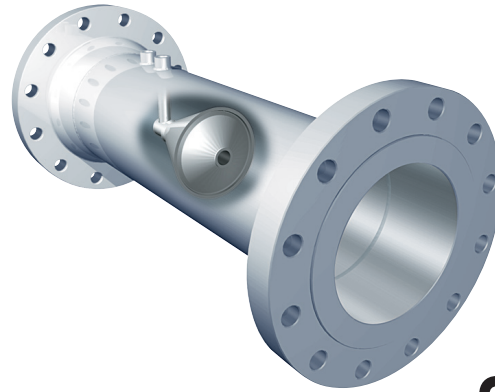

# Proven Flow Measurement Solutions for the Oil and Gas Industry



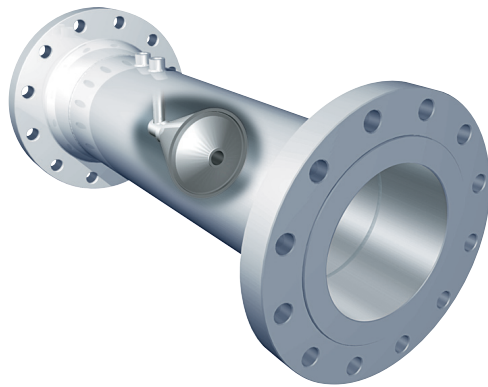

The V-Cone® flow meter is an advanced technology that takes differential pressure flow measurement to a new level. The V-Cone flow meter has proven its performance in the oil and gas industry in some of the harshest operating conditions and for the widest variety of fluid types. In these applications, the V-Cone flow meter consistently outperforms traditional dP devices and other major flow technologies.

### Low Installed Cost

Because it does not require long straight pipe runs or flow conditioning devices, the V-Cone flow meter can fit into tight spaces. When retrofitting existing applications, the V-Cone flow meter typically fits right in place without having to re-engineer the piping layout.

This installation flexibility saves cost, space and minimizes weight penalty problems without compromising the accuracy of the measurements. Future changes to upstream or downstream piping configurations will not affect the performance of the V-Cone flow meter.

### Wide Range of Flows and Fluids

The V-Cone flow meter handles most every flow condition because it acts as its own flow conditioner. This not only allows maximum installation flexibility, but accurate measurement of disturbed or swirling flows. In addition, the V-Cone flow meter is designed to withstand abrasive, dirty and particle-laden flows without significant wear.

### Ideal for Wet Gas and Steam

The V-Cone flow meter's ability to measure wet gas, steam, or condensate is unique in the industry. In side-by-side tests with other dP technologies, only the V-Cone flow meter provided accurate measurement of these challenging flow regimes.

### Superior Performance

The V-Cone flow meter delivers an accuracy to  $\pm 0.5\%$  of rate and  $\pm 0.1\%$  repeatability (depending on fluid type) under a variety of conditions. It also handles turndowns of 10:1 and greater, without loss of accuracy. The V-Cone flow meter has an unprecedented long life of twenty-five years or more.

## Meeting the Needs of the Oil & Gas Industry

Applications	Fluid Types
Allocation Measurement	Natural Gas / Crude Oil / Water / Air / Steam
Blending	Liquid Hydrocarbons / Chemicals
Burners	Natural Gas / LPG / LNG
Chimney Stack	Flue Gas
Coal Bed Methane / Shale Gas	Dirty / Wet Natural Gas
Compressors (Inlet / Outlet, Loop / Anti-Surge Control)	Natural Gas
Custody Transfer	Natural Gas / Crude Oil / Water / Air / Steam
Feed Lines to Flare	Natural Gas
Firewater Pumps Testing	Water / Seawater
Fuel Gas	Natural Gas / LPG / LNG
Gas Lift	Natural Gas
Injections / Reinjections	Natural Gas / Water / Steam / CO <sub>2</sub> (Gas & Liquid) / Chemical
Oil Sands	Steam / Natural Gas / Crude Oil
Produced Liquids	Liquid Hydrocarbons / Condensate / Water
Production and Test Separators (Inlet/Outlet)	Natural Gas / Wet Natural Gas / Crude Oil / Water
Lift Pumps	Water / Seawater
Steam	Saturated / Super Saturated / Super Heated
Wellhead Measurement	Natural Gas / Wet Natural Gas / Crude Oil / Water
Wet Gas (with Known Liquid Volume)	Wet Natural Gas

# So Innovative. . .

## It Created An Entirely New Category

After more than twenty years, McCrometer's V-Cone flow meter remains the most innovative dP meter available today. The self-conditioning cone is a simple, yet powerful way to provide accuracy you can count on regardless of flow dynamics. This results in maximum installation flexibility and unsurpassed performance.

### Low Total Cost of Ownership

With no moving parts to replace or maintain, the V-Cone flow meter assures long-term performance without the operating costs of other flow meters. The contoured aerodynamic shape of the cone profiles the flow in the pipe without impacting it against a sharp beta edge. Instead, a boundary layer forms along the cone, directing fluid away from the beta edge. The V-Cone flow meter's beta edge does not change dimensionally, thus allowing extremely long usage without physical re-calibration.

### Design Flexibility

The V-Cone flow meter is available in line sizes from 0.5" to greater than 120" in an extensive variety of construction materials with beta ratios to suit any application. The V-Cone flow meter can be jacketed, painted, coated, or treated like any other piece of piping. The V-Cone flow meter is regularly calibrated, tested and certified to the most demanding specifications.



*The Wafer-Cone® flow meter is the ideal low cost solution, offering exceptional flexibility for natural gas, coal bed methane, and shale gas wellheads. Also ideal for small process lines, and many other plant infrastructure applications.*

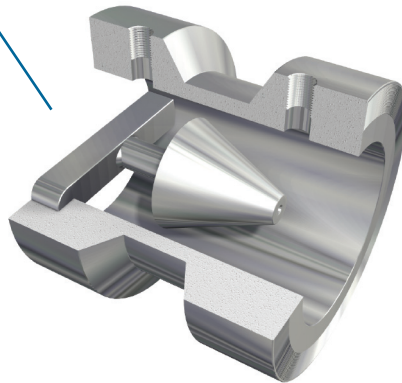

*The Wafer-Cone flow meter is available in line sizes from 1 to 6 inches and can be oil or gas flow calibrated. Featuring a removable cone and flangeless design, cones with different beta ratios can be easily exchanged to accommodate changing flow conditions without the need for recalibration.*

To place an order or learn more about the V-Cone flow meter, contact our

# V-Cone flow meter Specifications

<b>Standard Accuracy:</b>	± 0.5% of rate (certain fluids and Reynolds number applications may require specific calibrations to achieve this value)
<b>Repeatability:</b>	±0.1% or better
<b>Flow Ranges:</b>	10:1 and greater
<b>Standard Beta Ratios:</b>	0.45 through 0.85, custom betas available
<b>Head Loss:</b>	Varies with beta ratio and dP
<b>Installation Piping Requirements:</b>	Typically 0-3 diameters upstream and 0-1 diameter downstream of the cone are required, depending on fittings or valves in the adjacent pipeline
<b>Materials of Construction Include:</b>	S304, S316, Duplex 2205 and 2507, Carbon steels, Hastelloy C276, 6Mo, other materials are available on request
<b>Line Sizes:</b>	0.5" to 120" or larger
<b>End Fittings:</b>	Flanged, threaded, hub or weld-end standard - Others on request
<b>Configurations:</b>	Precision flow tube and wafer-type <ul style="list-style-type: none"><li>• Calibrated for customer application</li><li>• ASME B31.3 standard</li><li>• ASME B31.1, B31.4, B31.8, Sec. VIII, API 6A, and other standards available on request</li></ul>
<b>Approvals for the V-Cone Flow Meter:</b>	<ul style="list-style-type: none"><li>• GOST-R approval</li><li>• Canadian custody transfer approved</li><li>• In-Metro approved</li><li>• Meters in compliance with PED97/23/EC are available upon request</li><li>• ISO 9001:2008 certified quality management system</li></ul>
<b>Performance Verification Testing:</b>	<ul style="list-style-type: none"><li>• Tested at an API Registered MPMS Test Facility according to the requirements of API MPMS Chapter 22.2.</li></ul>



*McCrometer's innovative V-Cone flow meter is designed for high performance in mild to harsh environments.*

*This proven flow meter measures the widest range of fluids from liquids to gases, including wet gas, condensate, and dirty or abrasive flows, as well as other typical flow measurement conditions. The V-Cone flow meter offers easy installation, superior accuracy and repeatability, and long-term, low-cost operation for refinery and onshore/offshore production and delivery applications.*



**minimal straight  
pipe requirements**

•

**high accuracy and  
repeatability**

•

**low headloss**

•

**easy installation  
- ideal retrofit!**

•

**conditions  
disturbed flows**

•

**measures dirty and  
abrasive flows**

•

**virtually no  
maintenance**

•

**no recalibration**

•

**unprecedented  
long life**

# Advanced Differential Pressure Flow meter Technology

Pipe flow profiles are rarely ideal. Practically any change to the piping can disturb the flow. The contoured shape of the centrally located cone in the V-Cone flow meter overcomes this by reshaping the velocity profile.

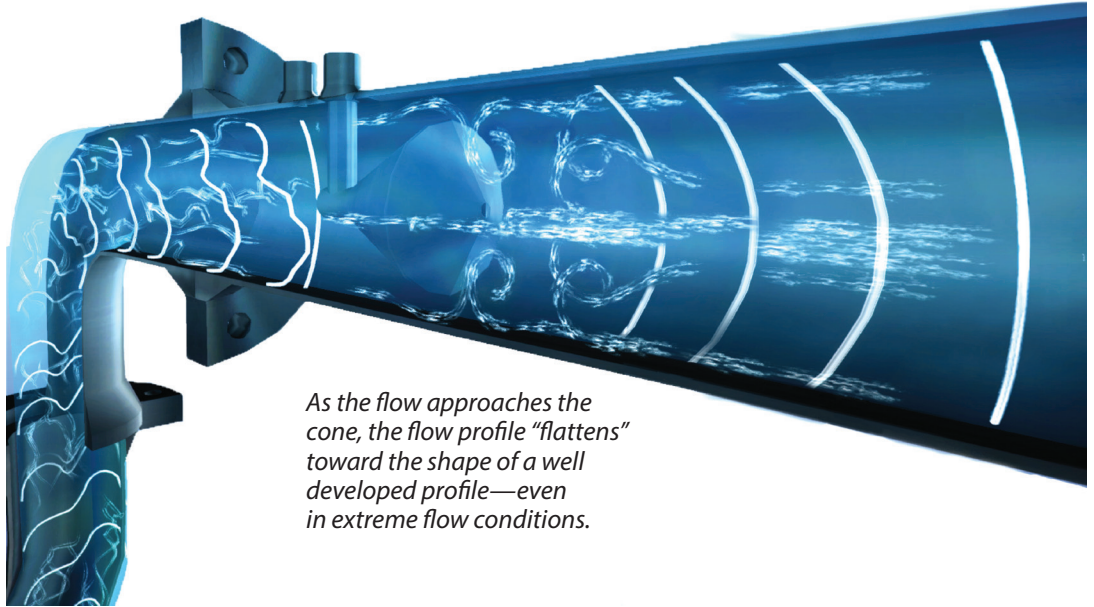

As the flow approaches the cone, the flow profile "flattens" toward the shape of a well developed profile—even in extreme flow conditions.

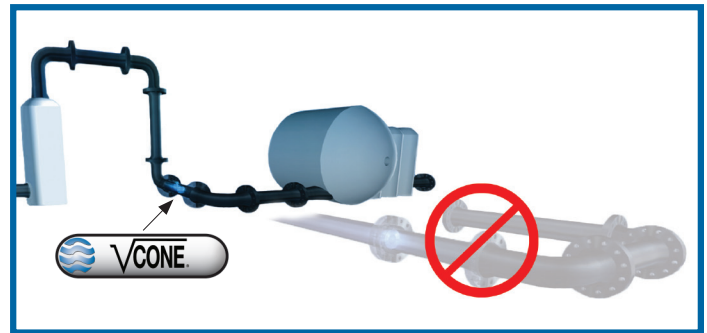
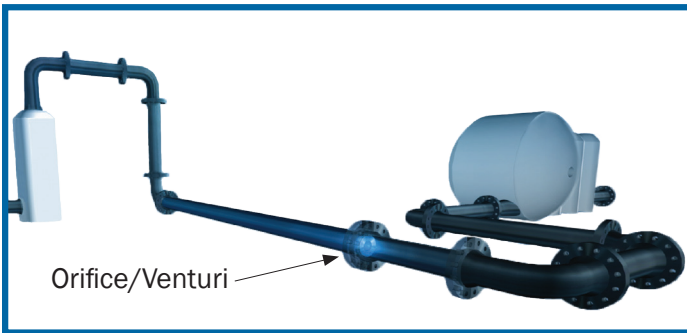

For over two decades, the oil and gas industry has turned to the V-Cone flow meter for flow measurement solutions. Consistently, this advanced flow meter has provided a level of performance thought unachievable in real-world environments.

Whether your application is straight-forward or challenged by limited installation space, disturbed flow, high turndowns, wet gas, or dirty or abrasive fluids, McCrometer's knowledgeable staff can accurately evaluate your application and specify the best meter to meet your needs.

**DASTECS** S.R.L.

Representantes / Distribuidores Exclusivos

Buenos Aires, Argentina  
Tel.: (54 - 11) 5352-2500  
Email: info@dastecsrl.com.ar  
Web: www.dastecsrl.com.ar

 **McCROMETER**

[www.mccrometer.com](http://www.mccrometer.com)

3255 West Stetson Avenue, Hemet, California 92545 USA  
Phone 800-220-2279 | 951-652-6811 | Fax 951-652-3078

© 2010-2013 McCrometer, Inc. Printed in U.S.A. Lit. Number 24519-15 Rev 1.9 / 07-13  
May be covered by one or more patents, including U.S. Patents 5,363,699 and 5,814,738 and counterparts outside the U.S. for foreign patents pending. V-Cone® and Wafer-Cone® are registered trademarks of McCrometer, Inc.