

Model P-950 Viscosity Index Analyzer



On-line Dual-bath Viscosity Index Analyzer for continuous measurement of absolute or dynamic viscosity and viscosity index of Newtonian fluids

- ▶ Customizable 2-4000 cP Sample Range (optional kinematic output in cSt)
- ▶ Continuous Sample Viscosity and Viscosity Index output
- ▶ Does not require atmospheric recovery system
- ▶ Superior repeatability exceeding ASTM D-445 and D-2270
- ▶ Remote diagnostics over IP



The Model P-950 Viscosity Index Analyzer is the result of combining the latest, state-of-the-art technology with over 45 years of industry experience. The result is an unsurpassed, high-quality viscosity measurement system that produces the process control signal required to perform today's optimized and cost-efficient petroleum refining operations.

This updated design combines traditional, reliable oil bath viscosity with key systems control upgrades. With the end user in mind, attention to design detail allows for ease of maintenance previously thought unattainable by conventional systems.

Model P-950 Viscosity Index Analyzer

APPLICATION

Given today's highly competitive environment, oil refiners are demanding instrumentation that aids in the optimization of the refining process. Therefore, refineries require a reliable and accurate viscosity analysis system to meet the required specifications. This analysis will allow the operators to optimize the refining process and therefore lower production costs while improving product quality.

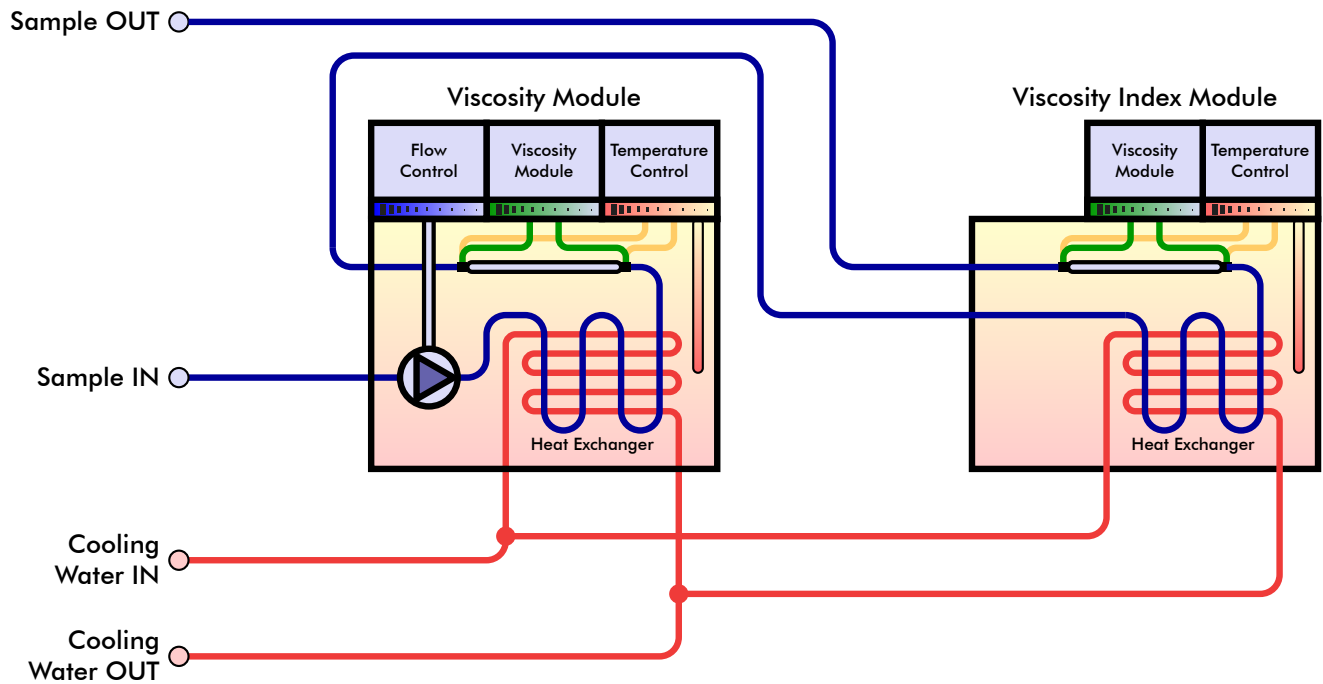

OPERATING PRINCIPLE

The P-950 measurement cycle is designed to correlate to the ASTM Method D-445. The measurement itself is based on the Hagan-Poiseuille principle, which states that a fluid's pressure differential across a capillary will vary proportionally to the fluid's absolute viscosity.

Sample is continuously refreshed via a bypass line on the instrument. A filtered sample slipstream is pulled from this line into the microprocessor controlled heat exchanger oil bath which brings the sample temperature to the specified measuring temperature. An AC synchronous motor and dual precision pumping system simultaneously raises the sample pressure to a preset limit and pushes a small portion of this sample through a capillary restriction where the pressure is measured at both ends. This pressure differential is recorded by the instrument and a corresponding absolute viscosity is output. . An optional kinematic viscosity output package allows the end user to program fixed or enter assigned sample densities for an output of kinematic viscosity.

While continuously streaming viscosity data output, the P-950 also monitors several system parameters in order to assure a reliable measurement. Sample inlet temperature, bath temperature, and bath oil level are all continuously monitored to assure system reliability. An optional customizable sample conditioning system can be added to handle samples of extreme temperatures and/or heavy particulates.

DIMENSIONS inch (mm)

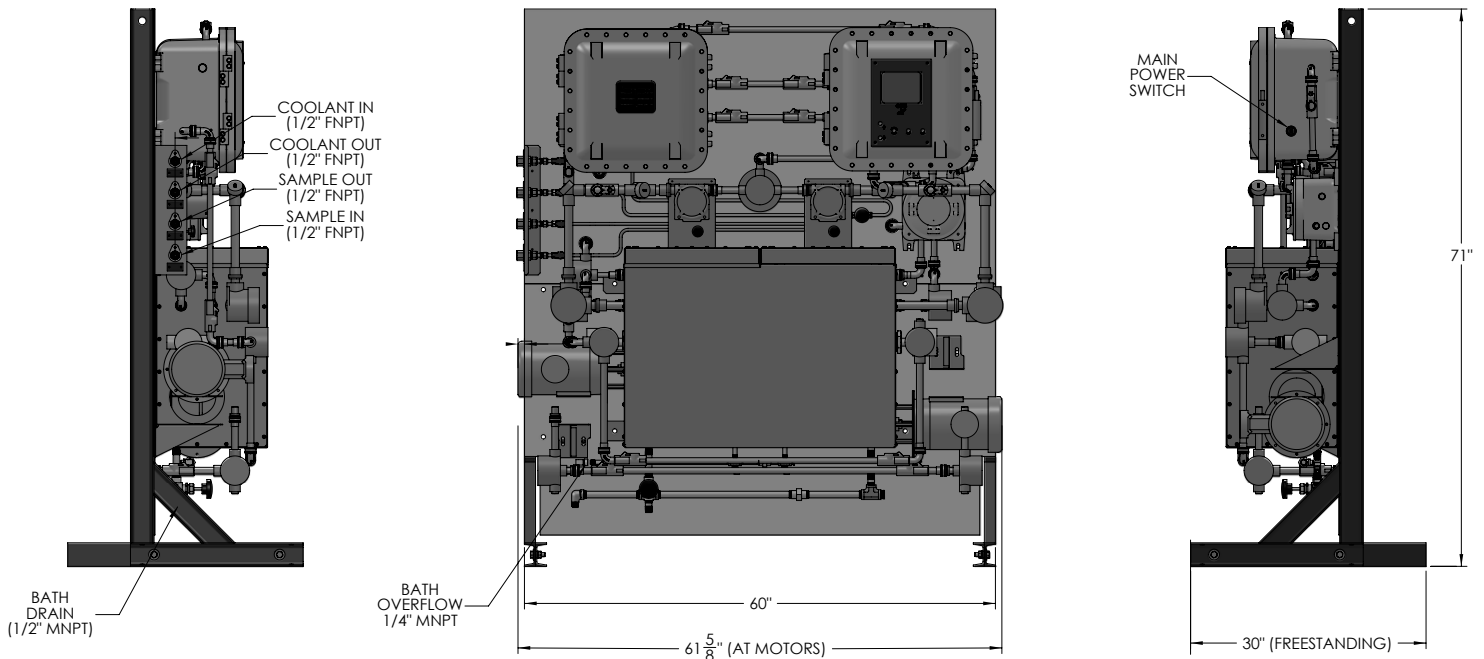



PRODUCT GUIDE

Petroleum Analyzers

- Cloud Point
- Cold Properties
- Flash Point
- Freeze Point
- Pour Point
- RVP
- RVP /VL20
- Salt-in-Crude
- Viscosity
- Viscosity Index

Other Products

- UV-Oil in Water
- Environmental Cabinets
- Sample Conditioning Systems
- Sample Recovery Systems
- Shelter Systems
- Spare Parts

Analyzer Services

- Field Service
- Start-Up & Commissioning
- Training
- Technical Support

SPECIFICATIONS: MODEL P-950 VISCOSITY INDEX ANALYZER

| ANALYSIS PERFORMANCE | |
|-------------------------------------|--|
| Measurement Cycle Time | Continuous |
| Measurement Range | 2-4000 cP, Customizable Based on Capillary Specification |
| Repeatability | ± 1% Full Scale |
| Reproducibility | Meets or exceeds ASTM Method D-445 |
| Accuracy | Meets or exceeds ASTM Method D-445 |
| Temperature Accuracy | ± .2°F (0.1°C) |
| SAMPLE REQUIREMENTS | |
| Sample Flow Rate | Min. 2 gal/hr (125 mL/min) |
| Sample Return Pressure | Atmospheric – Max. 150 psi (10 bar) |
| Sample Pressure | Min. 20 psi (1.4 bar) – Max. 200 psi (14 bar) |
| Sample Temperature | ± 100°F (38°C) of bath temperature set point |
| Sample Particulates | less than 10 µm - optional sample conditioning system available |
| Sample Conditions | homogenous, single-phase sample without free water |
| ENCLOSURE/INSTALLATION REQUIREMENTS | |
| Dimensions | 62" (1575) Width – 71" (1803) Height – 30" (381) Depth |
| Weight | approximately 650lbs. (295kg) |
| Operating Temperature | Min. 40°F (5°C) – Max. 105°F (40°C) |
| Enclosure Material/Rating | stainless steel - NEMA 4X / IP65 / ATEX rated Ex-Proof Enclosures |
| Area Classification | NEC Class 1 Div 1 Group C & D or ATEX Zone1 II B + H2 T4 |
| Power | 100 to 125VAC or 200 to 240 VAC, 50/60 Hz, single phase, 20A |
| Coolant/Steam Supply | 0.5 gal/min (2 l/min) maximum at 10°F (6°C) below bath set point |
| END USER CONNECTIONS | |
| Analog Output Signal | 4 isolated 4-20 mA output (optional second output available), selectable for sample Viscosity values, analyzer system/maintenance warning or analysis measurement indication |
| Relay Output Contact | three SPDT Relays with contacts rated at 3A resistive load at 250VAC, selectable for sample Viscosity value alarm, analyzer maintenance warning or analyzer fault alarm |
| Serial Input/Output Signal | TCP/IP or Serial/RTU ModBus output available |

HOW TO ORDER

| ANALYZER SYSTEMS | |
|---------------------------|---|
| Catalog Number P-950-1400 | ORB Model P-950 Viscosity Index Analyzer, NEC Explosion Proof |
| Catalog Number P-950-1500 | ORB Model P-950 Viscosity Analyzer, ATEX Explosion Proof |
| OPTIONS | |
| Catalog Number 700538 | Standard Panel Mount Sample Conditioning System |
| Catalog Number 700858 | MODBUS TCP/IP Protocol |
| ACCESSORIES | |
| Catalog Number 702285 | 1-Year Spare Parts Kit |
| Catalog Number 702286 | 2-Year Spare Parts Kit |

XPROOF ATEX/CE PURGED ATEX/CE PURGED ATEX/CE PURGED ULCSA/CSA GENERAL PURPOSE



Representantes / Distribuidores Exclusivos

Argentina

Tel: (+54 11) 5352 2500

Email: info@dastecsrl.com.ar

Web: www.dastecsrl.com.ar

Uruguay www.dastecsrl.com.uy

Bolivia www.tecdas.com.bo



ORB Instruments, Inc.
4724 South Christiana
Chicago, IL 60632 / USA

Phone: + (1)
Fax: + (1)
Email: sal