

EL-FLOW[®] *Select*

Digital Thermal Mass Flow Meters and Controllers for Gases

> Introduction

Bronkhorst High-Tech B.V., the European market leader in thermal Mass Flow Meters/Controllers and Electronic Pressure Controllers, has many years experience in designing and manufacturing precise and reliable measurement and control devices. With a wide range of instruments, Bronkhorst[®] offers innovative solutions for many different applications in many different markets.

The instruments are made to customers' specification, in various styles, suitable for use in laboratory, industrial and hazardous areas, in such diverse applications as semiconductor and analytical installations, to name but two.

> EL-FLOW[®] *Select* series for Laboratory and Instrumentation

EL-FLOW[®] *Select* series Mass Flow Meters and Controllers for gas applications have a housing designed for laboratory and clean processing conditions. The instruments are truly unique in their capability to measure and control flow ranges between 0,014...0,7 ml_r/min and 8...1670 l_r/min with pressure rating between vacuum and 400 bar – all in one range of instruments. This versatility in flow ranges and in operating conditions has ensured that the EL-FLOW[®] *Select* series remains our most popular and field proven of instruments.

> State of the art digital design

Today's EL-FLOW[®] *Select* series are equipped with a digital pc-board, offering high accuracy, excellent temperature stability and fast response (settling times t_{90} down to 500 msec). The main digital pc-board contains all of the general functions needed for measurement and control. The EL-FLOW[®] *Select* design features Multi Gas / Multi Range functionality, providing (OEM-) customers with optimal flexibility and process efficiency. For more information see our 'MASS-FLOW *Select*' leaflet.

In addition to the standard RS232 output the instruments also offer analog I/O. Furthermore, an integrated interface board provides DeviceNet[™], PROFIBUS DP, Modbus, EtherCAT[®], PROFINET or FLOW-BUS protocols. The latter is a fieldbus based RS485, specifically designed by Bronkhorst for their mass flow metering and control solutions.



> Mass Flow Controllers for every application

The control valve can be furnished as integral part of an EL-FLOW[®] *Select* MFC, or as separate component. It is a proportional, electro-magnetic control valve with extremely fast and smooth control characteristics. With reference to the specific field of application there are different series of control valves. There is a standard direct acting valve for common applications, a pilot operated valve for high flow rates, the so-called Vary-P valve that can cope with 6 up to 400 bar ΔP and a bellows valve for applications with very low differential pressure.

> General EL-FLOW[®] *Select* features

- ◆ fast response, excellent repeatability
- ◆ high accuracy
- ◆ virtually pressure and temperature independent
- ◆ pressure ratings up to 400 bar
- ◆ optional metal sealed and downported constructions

> Digital features

- ◆ DeviceNet[™], PROFIBUS DP, Modbus-RTU/ASCII, EtherCAT[®], PROFINET or FLOW-BUS slave; RS232 interface
- ◆ optional Multi Gas / Multi Range functionality up to 10 bar
- ◆ storage of max. 8 calibration curves
- ◆ alarm and counter functions
- ◆ control characteristics user-configurable

DASTEC S.R.L.

Representantes / Distribuidores Exclusivos

Buenos Aires, Argentina
Tel.: (54 - 11) 5352-2500
Email: info@dastecsr.com.ar
Web: www.dastecsr.com.ar

Bronkhorst[®]

> Technical specifications

Measurement / control system

Accuracy (incl. linearity)	: standard: $\pm 0,5\%$ Rd plus $\pm 0,1\%$ FS
(based on actual calibration)	$\pm 0,8\%$ Rd plus $\pm 0,2\%$ FS for F-110C-005/F-200CV-005 $\pm 2\%$ FS for F-110C-002/F-200CV-002
Turndown	: 1 : 50 (in digital mode up to 1:187,5)
Repeatability	: $< 0,2\%$ Rd
Settling time (controller)	: standard: 1...2 seconds option: down to 500 msec
Control stability	: $< \pm 0,1\%$ FS (typical for 1 l _v /min N ₂)
Operating temperature	: -10...+70°C
Temperature sensitivity	: zero: $< 0,05\%$ FS/°C; span: $< 0,05\%$ Rd/°C
Pressure sensitivity	: 0,1% Rd/bar typical N ₂ ; 0,01% Rd/bar typical H ₂
Leak integrity, outboard	: tested $< 2 \times 10^{-9}$ mbar l/s He
Attitude sensitivity	: max. error at 90° off horizontal 0,2% at 1 bar, typical N ₂
Warm-up time	: 30 min. for optimum accuracy 2 min. for accuracy $\pm 2\%$ FS

Mechanical parts

Material (wetted parts)	: stainless steel 316L or comparable
Process connections	: compression type or face seal couplings
Seals	: standard: Viton®; options: EPDM, Kalrez® (FFKM)
Ingress protection (housing)	: IP40

Electrical properties

Power supply	: +15...24 Vdc
Max. power consumption	: Supply at voltage I/O at current I/O
	Meter: 15 V 95 mA 125 mA
	24 V 65 mA 85 mA
	Controller: 15 V 290 mA 320 mA
	24 V 200 mA 215 mA
Extra for fieldbus:	PROFIBUS DP: add 53 mA (at 15 V) or 30 mA (at 24 V)
(if applicable)	EtherCAT®: add 66 mA (at 15 V) or 41 mA (at 24 V)
	PROFINET: add 77 mA (15 V supply) or 48 mA (24 V supply)
	DeviceNet™: add 48 mA (at 24 V)
Analog output/command	: 0...5 (10) Vdc or 0 (4)...20 mA (sourcing output)
Digital communication	: standard: RS232 options: PROFIBUS DP, DeviceNet™, EtherCAT®, Modbus-RTU/ASCII, PROFINET, FLOW-BUS
Electrical	
Analog/RS232	: 9-pin D-connector (male);
PROFIBUS DP	: bus: 9-pin D-connector (female); power: 9-pin D-connector (male);
DeviceNet™	: 5-pin M12-connector (male);
EtherCAT®/ PROFINET	: 2 x RJ45 modular jack (in/out)
FLOW-BUS/Modbus-RTU/ASCII	: RJ45 modular jack

Technical specifications and dimensions subject to change without notice.



F-111B Mass Flow Meter

> Models and flow ranges (based on Air)

Mass Flow Meters (MFM); PN100 (pressure rating 100 bar)

Model	min. flow	max. flow
F-110C	0,014...0,7 ml _v /min	0,06...9 ml _v /min
F-111B	0,16...8 l _v /min	0,16...25 l _v /min
F-111AC	0,4...20 l _v /min	0,6...100 l _v /min
F-112AC	0,8...40 l _v /min	1,4...250 l _v /min
F-113AC	4...200 l _v /min	8...1670 l _v /min

For ranges of 200 or 400 bar rated MFMs see model number identification.

Mass Flow Controllers (MFC); PN64 / PN100

Model	min. flow	max. flow
F-200CV/F-210CV ¹⁾	0,014...0,7 ml _v /min	0,06...9 ml _v /min
F-201CV/F-211CV ¹⁾	0,16...8 l _v /min	0,16...25 l _v /min
F-201AV/F-211AV ¹⁾	0,4...20 l _v /min	0,6...100 l _v /min
F-202AV/F-212AV ²⁾	0,8...40 l _v /min	1,4...250 l _v /min
F-203AV/F-213AV ³⁾	4...200 l _v /min	8...1670 l _v /min

¹⁾ K_v-max = 6,6 x 10⁻²

²⁾ K_v-max = 0,4

³⁾ K_v-max = 1,5

MFCs for high-pressure / high-ΔP applications; PN400

Model	min. flow	max. flow
F-230M	0,2...10 ml _v /min	10...500 ml _v /min
F-231M	10...500 ml _v /min	0,2...10 l _v /min
F-232M	0,2...10 l _v /min	2...100 l _v /min

> Thermal mass flow measuring principle

The heart of the thermal mass flow meter/controller is the sensor, that consists of a stainless steel capillary tube with resistance thermometer elements. A part of the gas flows through this bypass sensor, and is warmed up by heating elements. Consequently the measured temperatures T₁ and T₂ drift apart. The temperature difference is directly proportional to mass flow through the sensor. In the main channel Bronkhorst applies a patented laminar flow element consisting of a stack of stainless steel discs with precision-etched flow channels. Thanks to the perfect flow-split the sensor output is proportional to the total mass flow rate.

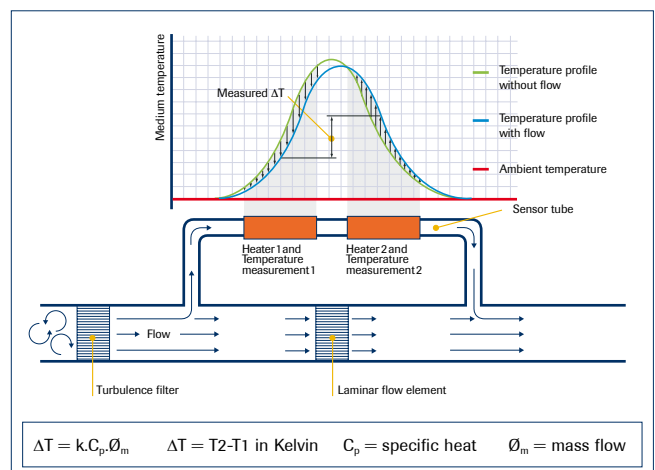

> Dimensions

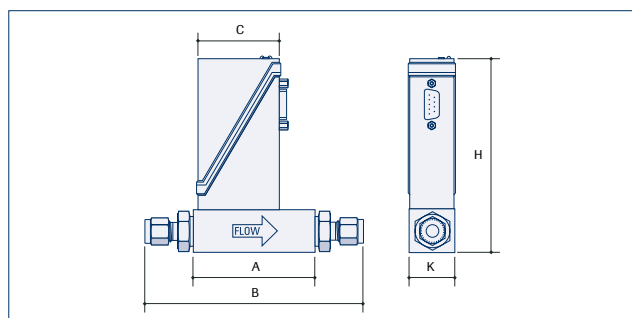

Mass Flow Meter

Model	A	B	C	H	K	Weight (kg)
F-110C (1/8" OD)	47	98	47	111	25	0,4
F-111B (1/4" OD)	69	126	47	111	25	0,5
F-111AC (1/4" OD)	69	126	47	123	26	0,6
F-112AC (1/2" OD)	65	130	47	139	59	1,3
F-113AC (1/2" OD)	112	179	47	153	74	3,0

Dimensions in mm.

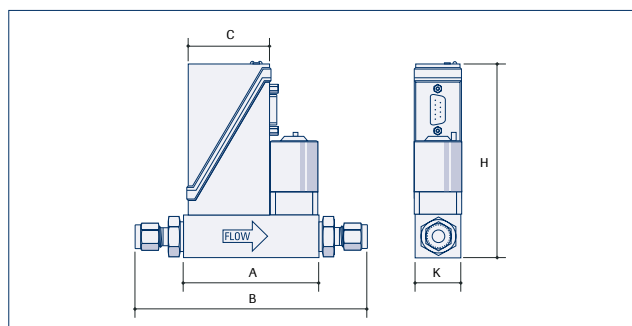

Mass Flow Controller

Model	A	B	C	H	K	Weight (kg)
F-200CV/F-210CV (1/8" OD)	77	128	47	111	25	0,6
F-201CV/F-211CV (1/4" OD)	77	134	47	111	25	0,6
F-201AV/F-211CV (1/4" OD)	78	135	47	123	26	0,7
F-202AV/F-212AV (1/2" OD)	112	169	47	139	59	2,1
F-203AV/F-213AV (1/2" OD)	171	238	47	153	74	4,9
F-220M/F-221M (1/4" OD)	85	139	47	126	28	0,9
F-230M/F-231M/F-232M (1/4" OD)	115	172	47	163	69	3,4

Dimensions in mm.

> Fields of application

The EL-FLOW® series have been successfully applied in a wide variety of both OEM and laboratory applications in the following markets (typically):

- ◆ Semiconductor processing
- ◆ Analysis and environmental measurements
- ◆ Burner control
- ◆ Vacuum technology
- ◆ Surface treatment installations
- ◆ Process control in food, pharmaceutical and (petro-) chemical industries

To give an impression of the many varied applications, we hereby sketch some basic examples. In reality, these applications are commonly far more complex and with far more variations and adaptations.

> Burner control

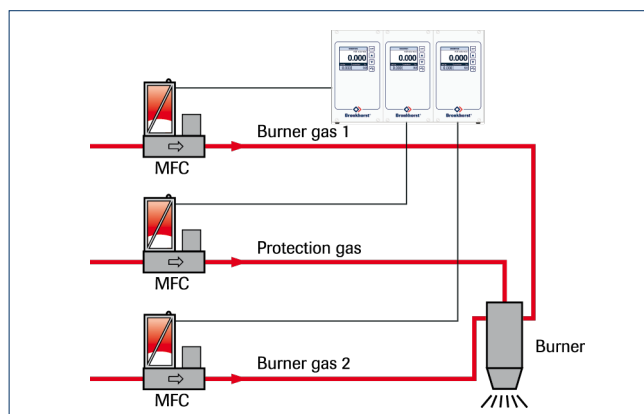

Burner control using Mass Flow Controllers brings many advantages compared to conventional systems, where flow is adjusted through needle valves. When burner orifices get clogged or when gas supply pressure varies, an MFC will automatically adapt to the changed conditions. For the control of relatively large flows with low differential pressure, which is typical for natural gas or CH₄, Bronkhorst offers mass flow meters with separate pressure compensated bellows valves.

> Making gas mixtures

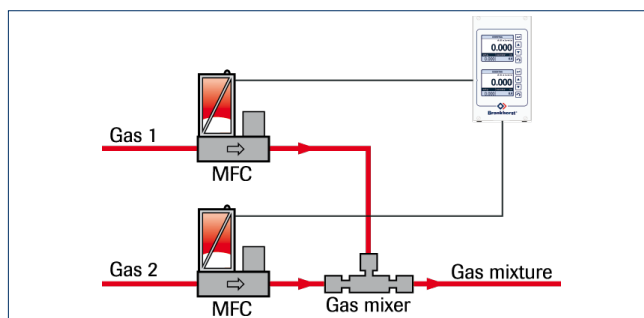

MFC's are often used to make precise and stable mixtures of two or more gases. A Bronkhorst® PS/Readout system can be applied to maintain the ratio of mixed gases by operating in master-slave mode. In the example above, the flow range of gas 1 is much smaller than the other. For this purpose Bronkhorst developed a gas mixer, to guarantee a homogeneous gas mixture.

> Feeding of reactors

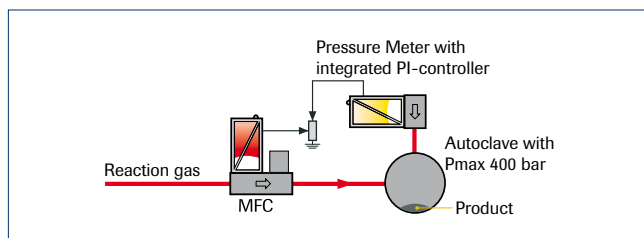

Flow control is often combined with the control of reactor pressure, using an EL-PRESS back pressure controller, or as depicted, an EL-PRESS Pressure Meter with integrated PI-controller. Typical applications: high pressure hydrogenation systems and autoclave processes using a 400 bar rated Mass Flow Controller with Vary-P control valve.

> Model number identification

F - N N NAA - NNN - A A A - NN - A

Base

0	Valve only
1	Meter
2	Controller

Pressure rating

0	64 bar
1	100 bar
2	200 bar
3	400 bar

Ranges

for PN64/PN100 Flow Meters/Controllers

0C/0CV	0...0,7 / 0...9 ml _v /min
1B/1CV	0...8 / 0...25000 ml _v /min
1AC/1AV	0...20 / 0...100 l _v /min
2AC/2AV	0...40 / 0...250 l _v /min
3AC/3AV	0...200 / 0...1670 l _v /min

for PN200/PN400 Flow Meters

0M	0...10 / 0...15 ml _v /min
1M	0...15 / 0...20000 ml _v /min
2M	0...10 / 0...250 l _v /min
3M	0...200 / 0...1250 l _v /min

for PN200 Flow Controllers

0M	0...100 / 0...15 ml _v /min
1M	0...15 / 0...20000 ml _v /min

for PN400 Flow Controllers

0M	0...10 / 0...500 ml _v /min
1M	0...0,5 / 0...10 l _v /min
2M	0...10 / 0...100 l _v /min

Nominal range

Factory selected

Communication (I/O)

A	RS232 + analog (n/c control)
B	RS232 + analog (n/o control)
D	RS232 + DeviceNet™ (n/c control)
E	RS232 + DeviceNet™ (n/o control)
M	RS232 + Modbus (n/c control)
N	RS232 + Modbus (n/o control)
P	RS232 + PROFIBUS (n/c control)
Q	RS232 + PROFIBUS (n/o control)
R	RS232 + FLOW-BUS (n/c control)
S	RS232 + FLOW-BUS (n/o control)
T	RS232 + EtherCAT® (n/c control)
U	RS232 + EtherCAT® (n/o control)
V	RS232 + PROFINET (n/c control)
W	RS232 + PROFINET (n/o control)

Analog output

A	0...5 Vdc
B	0...10 Vdc
F	0...20 mA sourcing
G	4...20 mA sourcing

Supply voltage

D +15...24 Vdc

Connections (in/out)

1	1/8" OD compression type
2	1/4" OD compression type
3	6 mm OD compression type
4	12 mm OD compression type
5	1/2" OD compression type
6	20 mm OD compression type
8	1/4" Face seal male
9	other

Internal seals

V	Viton® (factory standard)
E	EPDM
K	Kalrez® (FFKM)



F-203AV Mass Flow Controller for high flow applications

F-112AC Mass Flow Meter

F-231M Mass Flow Controller for high pressure applications

DASTEC S.R.L.

Representantes / Distribuidores Exclusivos

Buenos Aires, Argentina

Tel.: (54 - 11) 5352-2500

Email: info@dastecsr.com.ar

Web: www.dastecsr.com.ar

Bronkhorst®

Bronkhorst High-Tech B.V. Nijverheidsstraat 1a, NL-7261 AK Ruurlo Netherlands

T +31(0)573 45 88 00 F +31(0)573 45 88 08 I www.bronkhorst.com E info@bronkhorst.com



9.60.006F
©BHT-1163375